

Dual 1 In, 4 Out (Single 1 In, 8 Out) 3G/HD/SD/ASI/STM-1 Reclocking/Non-Reclocking Distribution Amplifier

FEATURES

- 4 in-phase reclocked / non-reclocked outputs on each amplifier.
- Switch selectable for 1 in, 8 out single distribution amplifier operation.
- Selectable for either 3G/HD/SD-SDI, ASI or STM-1 applications.
- Automatic output muting on no input.
- Optional relay bypass on loss of power.
- Front panel indicators provide monitoring of presence of inputs and lock status.
- SNMP monitoring and control.

GENERAL

The DDA-4009 serial digital data distribution amplifier provides the user with a single module to cover a wide range of distribution and monitoring functions for 3G/HD/ SD-SDI, ASI or STM-1 signals.

Two quad output reclocking / non-reclocking distribution amplifiers are provided on the one card. On board switch settings allow either of the inputs to feed all outputs to create a one in, eight out distribution amplifier.

BLOCK DIAGRAM DDA-4009 SIGNAL PATH

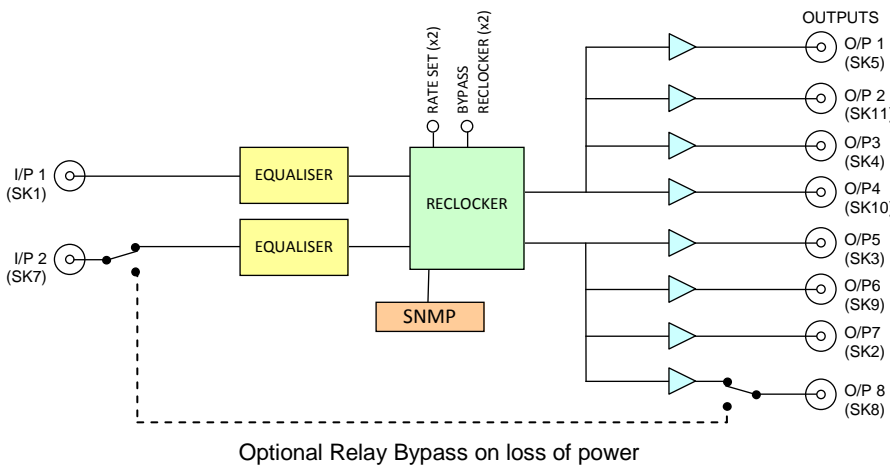

Where non-reclocking is required, on-board switch settings select between reclocking and non-reclocking modes.

The DDA-4009 will automatically reclock to match the input at either 3G-SDI, HD-SDI, SD-SDI, ASI or STM-1 rates, or can be fixed to operate at any one of these rates. Both sides of the DDA-4009 can be run independently allowing a mixture of signal types to be used.

Front panel LEDs indicate when input signals are present and whether the outputs are locked to the inputs.

An optional relay bypass rear assembly is available to switch one of the Inputs (I/P 2) to one of the Outputs in the event of a power failure.

Simple Network Management Protocol (SNMP) is available for remote setup and monitoring of input status and alarm states when used in an IRT frame fitted with SNMP capability.

The DDA-4009 is designed to fit IRT's 4000 series 3RU frame for use with IRT's SNMP system as well as being suitable with IRT's 1000 series 1RU Eurocard frames and may be used alongside any other of IRT's Eurocards.

I/P 1 & I/P 2 independently either 3G/HD/SD-SDI, ASI or STM-1 (STM-1 CMI encoded or NRZ encoded)

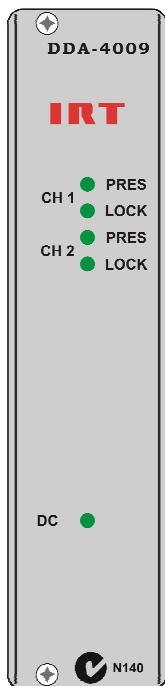

Standard Rear Assembly



Relay Bypass Rear Assembly

TECHNICAL SPECIFICATIONS

Data Inputs:

Number	2
Impedance	75 Ω , BNC.
Type	2.97Gb/s 3G-SDI, 1.485Gb/s HD-SDI, 270Mb/s SD-SDI/ASI, or 155Mb/s STM-1 (CMI or NRZ encoded).
Return loss	15dB 5 MHz to 1.485 GHz, 10dB from 1.485 GHz to 2.97 GHz.
Equalisation	Automatic 100 m at 2.97 Gb/s with Belden 1694A ¹ , 100 m at 1.485 Gb/s with Belden 8281 ¹ , 300 m at 270 Mb/s with Belden 8281 ² .
	NOTE 1 Reduces to 50m with optional bypass relay.
	2 Reduces to 160m when SW1-4 (I/P 1), SW2-4 (I/P 2) is ON.

Data Outputs:

Number	8 (1 in, 8 out; or (2x) 2 in, 4 out)
Type	Reclocked or non-reclocked, switch selectable.
Level	800 mV \pm 10% (3G/HD/SD-SDI / ASI / STM-1 NRZ encoded); 1.0 V. \pm 10% into 75 Ω (STM-1 CMI encoded).
Impedance	75 Ω , BNC.
Return loss	15dB 5 MHz to 1.485 GHz, 10dB from 1.485 GHz to 2.97 GHz.

Performance:

Reclocking	Automatic or selectable for 2.97Gb/s 3G-SDI, 1.485Gb/s HD-SDI, 270 Mb/s SD-SDI / ASI, or 155 Mb/s STM-1 operation.
Rise Time	3G/HD ~ 100ps; SD ~ 600ps.
Intrinsic Jitter	< 0.1 UI (measured with up to 300m of Belden 8281 or equivalent cable – reclocked mode).

Indicators:

DC	LED (green) for module power.
CH1 PRES	LED (green) when signal present on channel 1 input.
CH 1 LOCK	LED (green) when channel 1's outputs locked to incoming signal.
CH 2 PRES	LED (green) when signal present on channel 2 input.
CH 2 LOCK	LED (green) when channel 2's outputs locked to incoming signal.

Power requirement:

Voltage	28 Vac CT (14-0-14) or \pm 16 Vdc.
Power consumption	6 VA.

Other:

Temperature	0 - 50°C ambient.
Mechanical	Suitable for mounting in IRT 19" rack chassis with input, output and power connections on the rear panel.
Finish	Front panel Grey background, black lettering & red IRT logo. Rear assembly Detachable silk-screened PCB with direct mount connectors to Eurocard and external signals.
Dimensions	6 HP x 3 U x 220 mm IRT Eurocard.
Standard	Rear connector assembly with matching connector for alarm output.
Optional	ZDA-4009RL relay bypass rear assembly.